

Health o meter[®]

P r o f e s s i o n a l

Large Platform Digital Scale Model 2842KL



USER INSTRUCTIONS



PELSTAR, LLC 9500 West 55th St. McCook, IL 60525-7110 USA

www.homscales.com

© Pelstar, LLC 2016

Thank you for your purchase of this Health o meter® Professional scale. Please read this manual carefully and keep it for easy reference or training.

TABLE OF CONTENTS

CAUTIONS AND WARNINGS.....	3
SPECIFICATIONS.....	4
CERTIFICATIONS/DISPOSAL.....	5
ASSEMBLY INSTRUCTIONS	6
SET UP	9
OPERATING INSTRUCTIONS.....	10
MAINTENANCE	12
TROUBLESHOOTING	13
CALIBRATION	14
WARRANTY	15

Note: This scale has been factory calibrated, and does not require calibration prior to use.

Please register your scale for warranty coverage at:

www.homscales.com

For User Instructions updates and revisions please go to:

www.homscales.com

CAUTIONS AND WARNINGS

- To prevent injury, never leave patient unattended while on the scale.
- For accurate weighing the scale must be placed on a flat, stable surface.
- For accurate weighing, verify proper operation according to the procedure described in this manual before each use.
- Do not use in the presence of flammable materials.
- Do not transport the scale with any weight on the platform.
- Do not exceed recommended weight limit of 600 lb / 272 kg for this scale.
- Operating at other voltages and frequencies than specified could damage the equipment.
- If the “LO BAT” indicator activates, for accurate weighing, replace the batteries or connect the scale to an AC power source.
- If the scale becomes damaged, it should not be operated until properly serviced. All repairs should only be performed by authorized Health o meter® Professional service personnel.
- When replacing / inserting batteries, be sure to use all new batteries.
- To prevent patient injury, the patient must be attended throughout the entire weighing event.
- Operate this scale exclusively with the AC adapter provided by Health o meter® Professional. Use of an unspecified adapter will void the warranty, and can pose a serious safety hazard.
- For use with AC adapter model ADPT31.
- Prior to using this scale, inspect the AC adapter cord for cracking / fraying, or for broken / bent plug prongs.
- Prior to using this scale, ensure that the AC adapter is plugged into an outlet with the rated voltage appropriate for operation.
- Ensure that the AC adapter and scale do not come in contact with liquids, excessive temperature, or excessive humidity.
- Unplug the AC adapter, and carefully store both the adapter and adapter cord before moving the scale.

SPECIFICATIONS

Health o meter Professional's Large Platform Digital Scale model 2842KL uses highly sophisticated microprocessor technology. Each scale is designed to provide accurate, reliable and repeatable weight measurements and features that make the weighing process simple, fast and convenient.

- Weighing is performed by motion-sensing technology.
- The patient's weight can be displayed in pounds or in kilograms.
- The scale includes a specially designed removable rubber mat for easy cleaning.
- The unit can be operated using its AC power adapter or by 6 C-cell batteries.

SCALE SPECIFICATIONS

Capacity and Resolution:	600 lb x 0.2 lb (270 kg x 0.1 kg)
Power Requirements:	Adapter 120 VAC-9VDC 60Hz 200MA (ADPT31 INCLUDED), or 6 C-cell 1.5V batteries (not included)
Environmental:	Operating Temperature: 50°F to 95°F / 10°C to 35°C Storage Temperature: 30°F to 125°F (0°C to 50°C) Maximum Humidity: 85% RH in use or in storage
Platform Dimensions:	22 1/4" (w) x 42" (d) x 2 1/2" (h) / 565mm (w) x 1067mm (d) x 64mm (h)

CERTIFICATIONS / DISPOSAL

Certification Descriptions:

**ISO13485:2003
CERTIFIED**

Pelstar, LLC has been officially certified as a manufacturer of Health o meter® Professional medical devices to be in compliance with stringent ISO requirements. The Pelstar, LLC quality assurance system covers the development, production, sales and service of medical scales and measuring systems.

Scale Disposal:



Do not dispose of this device in domestic waste. This Health o meter® Professional scale must be disposed of properly as electronic waste. Follow the national, regional or local regulations which apply to you for disposal. For scale assistance or telephone support, please call Health o meter® Professional Customer Service (available on normal business days) at (+1) 800-815-6615 or (+1) 708-377-0600.

ASSEMBLY INSTRUCTIONS

Before Assembly

Each 2842KL Large Platform Digital Scale is shipped disassembled in one carton. Carefully inspect the carton for shipping damage before unpacking. If damage is found, contact your shipper or a Health o meter® Professional representative immediately at 1-800-815-6615. Claims must be filed with the shipper as soon as possible after receipt of the package. The following information details what you will find inside the main carton as you unpack the parts for assembly.

To prevent scratching any components, carefully remove each assembly from the carton and unwrap the packing materials. Set the carton aside for storage. To avoid damaging the scale parts when unpacking, do not use a box cutter, knife, scissors, or any sharp object to open the protective inner packaging.

Parts List

Carton

- (1) Base assembly
- (1) Display head
- (1) Display assembly bracket
- (4) Base assembly feet
- (1) Small white box containing AC adapter
- (2) Display assembly screws and washers
- (1) Rubber mat

ASSEMBLY INSTRUCTIONS (CONT.)

1. Place the base assembly upside down on a flat, steady surface.



2. Screw the four feet into the base assembly. Turn each foot completely into the base assembly and then back out 1 1/2 turns.



3. Carefully turn the base assembly right side up. Adjust the feet as necessary for a level, stable platform. Do not drop the scale as this may damage the load cells.

4. Place the display head into the display bracket and screw in the two display assembly screws. If wall mounting the display, complete this step after the display assembly bracket has been mounted to the wall.



ASSEMBLY INSTRUCTIONS (CONT.)

5. Plug the display cable connector into the base cable connector.	
6. Place the rubber mat in the center area of the base assembly platform.	
7. Place the display assembly on a table or mount it to a wall. See the next section for mounting instructions.	

Display Assembly Wall Mounting Instructions

Caution: When wall mounting the display assembly, ensure that the mounting location is free of electrical lines, gas pipes, and other safety hazards. Ensure that wall is of construction that can support the display assembly.

Note: Display assembly can be mounted to a wall up to 6 feet (1.83 m) from the base.

1. If display head is already attached to the display assembly bracket, remove the display assembly screws at the side of the display head and set them aside.
2. Position the display assembly bracket on the wall at the desired location and mark the mounting bracket hole locations.
3. Use suitable plastic or metal anchors for the type of wall construction and carefully drill the appropriate sized holes.
4. Insert the anchors into the wall, and screw the two mounting screws into the anchors. Adjust the screw head depth such that the screw heads protrude 1/8" (3.2 mm) from the wall.
5. Position the display assembly mounting holes onto the mounting screws and pull down on the display assembly to secure the bracket over the screws.
6. Re-attach the display head to the display assembly bracket using the two display assembly screws.

Required Parts Not Included With This Scale

- (2) # 10-12 x 1 in. Screws
- (2) Mounting anchors, compatible with wall construction

SET UP

1. Place batteries in the battery holder (see “Replacing Batteries” below).
2. Plug the scale’s AC adapter into the display assembly and into the power source.
3. Press the **ON/OFF** button to turn the scale on. The display will show “start” and then “0.0”.
4. When the self-test function is complete, the digital display should read “0.0”.
5. Place a weight [not to exceed 600 lb (270 kg)] on the scale. The digital display will blink “-----” until the weight calculation is complete.
6. Press the **LBS/KG** button to select the weight mode, either in kilograms or pounds.
7. Press the **REWEIGH** button; the digital display should again read the weight of the item on the scale.
8. Remove the weight from the scale. The digital display should continue to read the weight of the item that was on the scale.
9. Press the **ZERO** button; the digital display should return to zero.
10. Disconnect the power source from the scale, then turn the scale on using **ON/OFF** button. The scale should automatically switch to battery power.

NOTE: If the set up procedure failed, contact Health o meter Professional Scales Customer Service at 1-800-815-6615.

Replacing Batteries

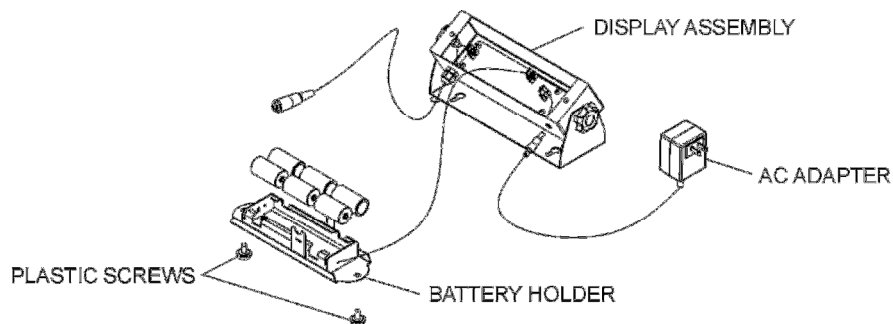

Figure 1. Replacing the Batteries

1. Disconnect the scale from the AC power source.
2. Unscrew two plastic screws and carefully remove the battery holder from the display assembly.
3. Take the batteries from the battery holder, replace the batteries with new ones.
4. Position the battery holder into the display assembly and reinstall two plastic screws.

OPERATING INSTRUCTIONS

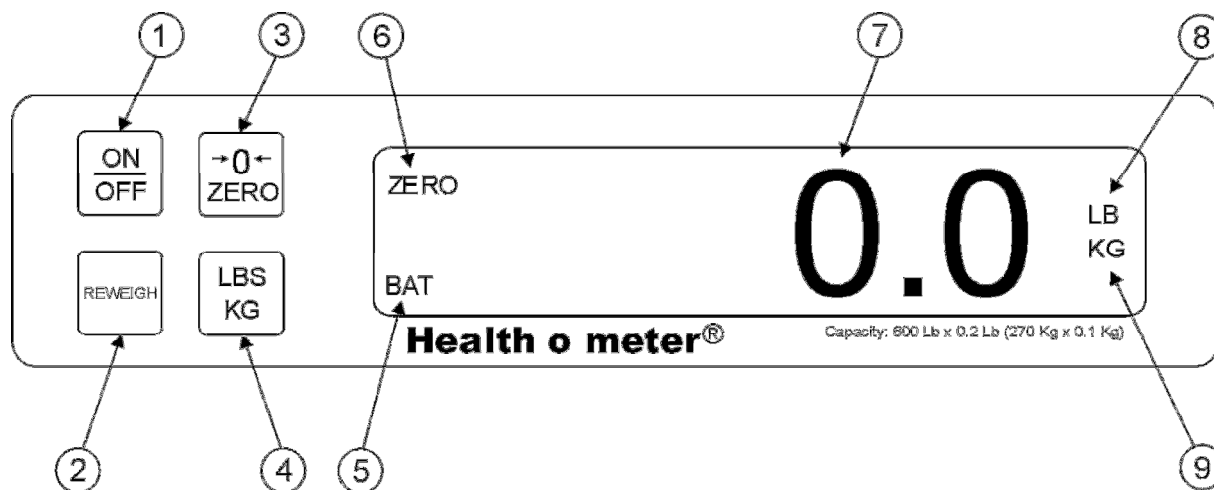

Figure 2. Control Panel

ITEM	DESCRIPTION	FUNCTION
1	ON/OFF button	Turns scale ON and OFF.
2	REWEIGH button	Allows repeated weighing of the patient without stepping off the scale.
3	ZERO button	Zeros digital display prior to weighing. Enables the cancellation (tare) of weight of mat or other accessories on the scale.
4	LBS/KG button	Selects kilograms or pounds.
5	BAT indicator	When ON, indicates scale batteries are low. The batteries should be replaced.
6	ZERO indicator	When ON, indicates the scale is stable and ready for use.
7	Digital Display 6 Digit LCD	Displays patient weight in kilograms or pounds as shown by the "LB" or "KG" indicator on the right side of the display. When REWEIGH button is depressed, display will blink "-----" until patient's weight is determined.
8	LB indicator	When ON, indicates displaying weight in pounds.
9	KG indicator	When ON, indicates displaying weight in kilograms.

OPERATING INSTRUCTIONS (CONT.)

1. Press the **ON/OFF** button to turn the scale on.
2. Wait until “0.0” appears on the digital display.
3. Place the patient on the scale. The display will blink “=====” until the weight of the patient is determined.
4. If you wish to reweigh the patient without removing them from the scale, press the **REWEIGH** button.
5. Remove the patient from the scale. The digital display will continue to read the patient’s weight until the **REWEIGH** or **ZERO** button is pressed.

NOTE: After 2 minutes of inactivity, the scale will turn off to conserve power. To restart the scale, press the **ON/OFF** button. (If it is powered by adapter, auto off function is disabled.)

Tare Function

When using this scale, the weight of an object, such as a blanket, can be subtracted from the total weight in order to determine the weight of the patient alone. Ensure that the edges of the object are on the scale and not touching the floor.

1. With all weight off the scale, press the ON/OFF button to turn on the scale.
2. Wait until the “0.0” appears on the display.
3. Place the object to be tared on the platform. The display will blink “=====” until the weight of the object is determined.
4. Do not remove the object. Then press the **ZERO** button.
5. Place the patient on the scale. The scale will automatically deduct the tare weight of the object from the gross weight of the patient and item together.
6. The weight of the patient will appear on the scale.
7. When the patient and the object are removed from the scale, the display will show “UL”.
8. To clear the tared weight, press the **ZERO** button.

MAINTENANCE

General

This section provides instructions for maintenance, cleaning, and troubleshooting for the Large Platform Digital Scale model 2842KL. Maintenance operations other than those described in this section should be performed by qualified service personnel such as Biomed or Engineering.

Maintenance

Before first use and after periods of non-use, check the scale for proper operation and function. If the scale does not operate correctly, refer to qualified service personnel such as Biomed or Engineering.

1. Check overall appearance of the total scale for any obvious damage, wear and tear.
2. Inspect AC adapter for cord cracking or fraying or for broken or bent prongs.

Cleaning

Proper care and cleaning is essential to ensure a long life of accurate and effective operation. Disconnect the scale from the AC power source.

1. Clean all external surfaces with a clean damp cloth or tissue. Mild soap and water solution may be used. Dry with a clean soft cloth.
2. Do not immerse the scale base or display assembly into cleaning or other liquid solution.
3. Do not use Isopropyl Alcohol or other solutions to clean the display surface.

TROUBLESHOOTING

Refer to the following instructions to check and correct any failure before contacting service personnel. Should you have further questions, call Health o meter® Professional Scales Customer Service at 1-800-815-6615.

SYMPTOM	POSSIBLE CAUSE	CORRECTIVE ACTION
Scale does not turn on	<ol style="list-style-type: none"> 1. Dead Battery 2. Faulty electrical outlet 3. Bad power supply 	<ol style="list-style-type: none"> 1. Replace batteries 2. Use a different outlet 3. Replace adapter
Questionable weight or the scale does not zero	<ol style="list-style-type: none"> 1. External object interfering with the scale 2. The display did not show "0.0" before weighing 3. Scale is not placed on a stable surface 4. Scale is out of calibration 	<ol style="list-style-type: none"> 1. Remove interfering object from the scale 2. Remove patient, zero the scale and begin weighing process again 3. Place the scale on a stable surface and begin weighing process again 4. Check weight with known weight value
The display shows "OL"	The load on the scale exceeds the capacity	Remove the excess weight and use the scale according to its capacity of 600 lb / 270 kg
The display shows "UL"	The scale is in under-load condition	Make sure the rubber mat is placed on the base. Or press ZERO to clear a previously tared weight.
The display shows "LO BAT"	The batteries are low	Replace batteries according to instructions

CALIBRATION

This scale has been factory calibrated, and does not require calibration prior to use. If required, the scale can be calibrated. The following calibration assumes the scale is set to pounds, and 200 lb is employed as the calibration standard.

Note: Only weights certified and traceable to national standards are to be used for calibration procedures.

Scale Calibration

ACTION	DISPLAY SHOWS
Press and hold the REWEIGH and ZERO buttons at the same time, while pressing the ON/OFF button to turn on the scale. "LOAD" will briefly appear on the display, followed by "200.0 LB" indicates you can calibrate. Release all three buttons.	"LOAD" followed by "200.0 LB"
Ensure there is no weight on the scale (except for the rubber mat) and press the REWEIGH button. "Clear" will flash on the display, followed by "-----". At this time the scale is calculating zero calibration. After zero calibration, the display will flash "PUT" followed by "200.0 LB".	"Clear" followed by "-----". Then "PUT" followed by "200.0 LB"
Place 200 lb on the scale. Then press REWEIGH . "CAL" will appear on the display, followed by "FAC" followed by 5 digits. The calibration factor should be in the range between 8000 and 10000. If the number is out of that range, contact Customer Service at 1-800-815-6615.	"CAL" followed by "FAC" followed by "X.XXXX".
If the calibration factor is within range, press the REWEIGH button. "DONE" will appear on the display, followed by "START", followed by "0.0". Remove the weight from the scale.	"DONE" followed by "START", followed by "0.0".
Calibration procedure is complete.	

WARRANTY

Limited Warranty

What does the Warranty Cover?

This Health o meter® Professional scale is warranted from date of purchase against defects of materials or in workmanship for a period of two (2) years. If product fails to function properly, return the product, freight prepaid and properly packed to Pelstar, LLC (see "To Get Warranty Service", below, for instructions). If the manufacturer determines that a defect of material or in workmanship exists, the customer's sole remedy will be replacement of the product at no charge. Replacement will be made with a new or remanufactured product or component. If the product is no longer available, replacement may be made with a similar product of equal or greater value. All replaced parts are covered only for the original warranty period.

Who is Covered?

The original purchaser of the product must have proof of purchase to receive warranty service. Please save your invoice or receipt. Pelstar dealers or retail stores selling Pelstar products do not have the right to alter, or modify or in any way change the terms and conditions of this warranty.

What is Excluded?

Your warranty does not cover normal wear of parts or damage resulting from any of the following: negligent use or misuse of the product, use on improper voltage or current, use contrary to the operating instructions, abuse including tampering, damage in transit, or unauthorized repair or alternations. Further, the warranty does not cover natural disasters, such as fire, flood, hurricanes and tornadoes. This warranty gives you specific legal rights, and you may also have other rights that vary from country to country, state to state, province to province or jurisdiction to jurisdiction.

To get Warranty Service make sure you keep your sales receipt or document showing proof of purchase. Call (+1) 800-638-3722 or (+1) 708-377-0600 to receive a return authorization (RA) number, which must be included on the return label. Attach your proof of purchase to your defective product along with your name, address, daytime telephone number and description of the problem. Carefully package the product and send with shipping and insurance prepaid to:

Pelstar, LLC
Attention R/A# _____
Return Department
9500 West 55th Street
McCook, IL 60525



PELSTAR, LLC

9500 West 55th Street • McCook, IL 60525 • USA

1-800-638-3722 or 1-708-377-0600

PLEASE REGISTER YOUR SCALE FOR WARRANTY COVERAGE AT:

www.homscales.com

Health o meter® is a registered trademark of Sunbeam Products, Inc. used under license.

Health o meter® Professional products are manufactured, designed, and owned by Pelstar, LLC.

We reserve the right to improve, enhance, or modify Health o meter® Professional product features or specifications without notice.

© Pelstar, LLC 2015

P/N UM2842KL Rev20160105

