



DC 3000 Series Crane Scale Instruction Manual



TABLE OF CONTENTS

1. INTRODUCTION	2
1.1 SAFETY PRECAUTIONS	2
1.2 SIZING THE SCALE (Important Note)	4
1.3 OVERVIEW OF PARTS AND CONTROLS	5
2. INSTALLATION	10
2.1 UNPACKING	10
2.2 HANGING THE SCALE	10
2.3 HANDLING HOIST MOTION	10
2.4 LOADING PROCEDURES	11
2.5 POWER SUPPLY	12
2.6 REMOTE CONTROLLER (Optional)	12
2.7 CALIBRATION	13
3. OPERATION	13
3.1 TURNING THE SCALE ON/OFF	13
3.2 ZERO OPERATION	13
3.3 TARE OPERATION	14
3.4 WEIGHING	14
3.5 ACCUMULATION	14
3.6 PEAK HOLD	16
3.7 DISPLAY HOLD	16
3.8 SLEEP MODE	16
4. SCALE SETTINGS	17
4.1 MENU STRUCTURE	17
4.2 MENU NAVIGATION	17
4.3 SCALE SETUP ACCESS	18
4.4 MENU ACCESS	21
5. LEGAL FOR TRADE	22
5.1 VERIFICATION	22
5.2 SEALING	22
6. MAINTENANCE	23
6.1 CLEANING	23
6.2 REGULAR MAINTENANCE AND INSPECTION	23
6.3 DISPLAY MESSAGES	25
6.4 SERVICE INFORMATION	25
7. TECHNICAL DATA	25
7.1 SPECIFICATIONS	25
7.2 DRAWINGS AND DIMENSIONS	26
7.3 COMPLIANCE	27

1. INTRODUCTION

This manual contains safety, installation, operation and maintenance instructions for the DC 3000 Series Crane Scale (Model DCR). Please read this manual completely before installation and operation.

1.1 SAFETY PRECAUTIONS

For safe and dependable operation of this equipment, please comply with the following safety precautions:



ONLY PERMIT QUALIFIED PERSONNEL TO SERVICE THIS EQUIPMENT. EXERCISE CARE WHEN MAKING CHECKS, TESTS, AND ADJUSTMENTS THAT MUST BE MADE WITH POWER ON. FAILURE TO OBSERVE THIS PRECAUTION COULD RESULT IN BODILY INJURY.



NEVER LIFT MORE THAN THE CRANE SCALE'S ASSIGNED WORKING LOAD LIMITED (WLL) RATING (SCALE CAPACITY).



NEVER POSITION THE LOAD OVER A HUMAN OR ANY BODY PART.

LOADS MAY DISENGAGE FROM THE CRANE SCALE HOOK AND SHACKLE IF PROPER PROCEDURES ARE NOT FOLLOWED.

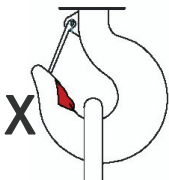

DO NOT USE ANY LOAD BEARING COMPONENT THAT IS WORN BEYOND 5% OF THE ORIGINAL DIMENSION.

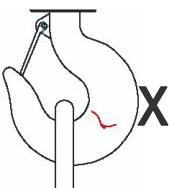

DO NOT USE THIS PRODUCT IF ANY OF THE COMPONENTS ARE CRACKED.

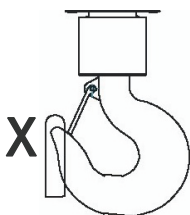

THE SAFETY LATCH MUST NEVER SUPPORT THE LOAD.

1.1 SAFETY PRECAUTIONS (cont.)



WARNINGS

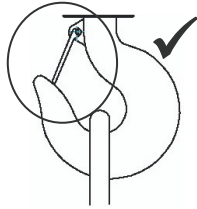

BOTH THE CRANE AND SCALE SAFETY LATCHES MUST BE IN GOOD CONDITION AND IN PLACE.

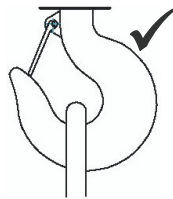

THE CRANE SCALE HOOK MUST ALWAYS SUPPORT THE LOAD CORRECTLY.

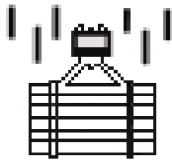

LOADS MAY DISENGAGE FROM THE CRANE SCALE HOOK AND SHACKLE IF PROPER PROCEDURES ARE NOT FOLLOWED.

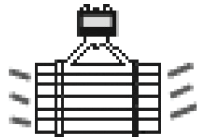

DO NOT LET LOADS SWING.



DO NOT LEAVE THE CONTROLS WHILE A LOAD IS SUSPENDED.



OPERATE THE CRANE AT A SAFE SPEED.

1.1 SAFETY PRECAUTIONS (cont.)



BEFORE OPERATING THE SCALE

- Follow all local and national safety laws.
- Follow all safety precautions from the crane manufacturer.
- **DO NOT** lift beyond the rated load capacity of the crane, crane scale, sling chains, cables, or any item attached to the crane scale.
- **DO NOT** operate the scale in areas designated for pedestrians—these are usually marked.
- **DO NOT** position or maneuver the scale or loads over any personnel.
- **DO NOT** use slings, cables, chains, etc. which have not been approved for lifting.
- **DO NOT** lift loads with ropes, slings, cables and chains that are not securely fastened around or to the load.
- **DO NOT** operate the crane scale if ropes, slings, cables, chains, etc. show any signs of defect or excessive wear
- Replace any damaged or worn items immediately.
- All ropes, slings, cables, chains, etc. should be removed from the crane scale when not in use.
- Before moving the load, make certain that load slings, load chains or other lifting devices are fully seated in the saddle of the crane scale hook, with the hook latch closed.
- At no time should a load be lift suspended from the crane scale unless the operator is at the crane's master switch or pendulum with the crane power on.
- Keep the load as close to the floor as possible to minimize the possibility of injury, should the load drop.
- When a hitcher is used, it should be the joint responsibility of the crane operator and the hitcher to ensure that hitches are secured, and that all loose material has been removed from the load before starting a lift.
- **DO NOT** pull or push a load when it is attached to the scale.
- **DO NOT** allow the load to swing when it is being moved.
- **DO NOT** make abrupt starts and stops with the crane, which could cause the loss of control of the load, or excessively strain the lifting mechanisms (ropes, slings, cables, chains, etc.).
- **DO NOT** drop the load when attached to the crane scale.
- **DO NOT** tilt the load too rapidly.
- **DO NOT** collide the crane scale against any object.
- **DO NOT** service or adjust the scale when a load is attached.

1.2 SIZING THE SCALE (Important Note)

How to choose the correct crane scale size:

Lifting capacity of the crane x Safety Factor = Proper scale size

- The scale capacity should be equal to or greater than the lifting capacity of the crane. For example, if a crane has a lifting capacity of 1.5 tons, a 2-ton scale is recommended.
- If a company has a safety program, regularly trains employees in safe crane operation, and continually inspects safety related hardware for proper operation, a safety factor of 1 may be used.
- If employees are not trained in safe crane operation and could overload the crane, use at least 2 as a safety factor.

1.3 OVERVIEW OF PARTS AND CONTROLS

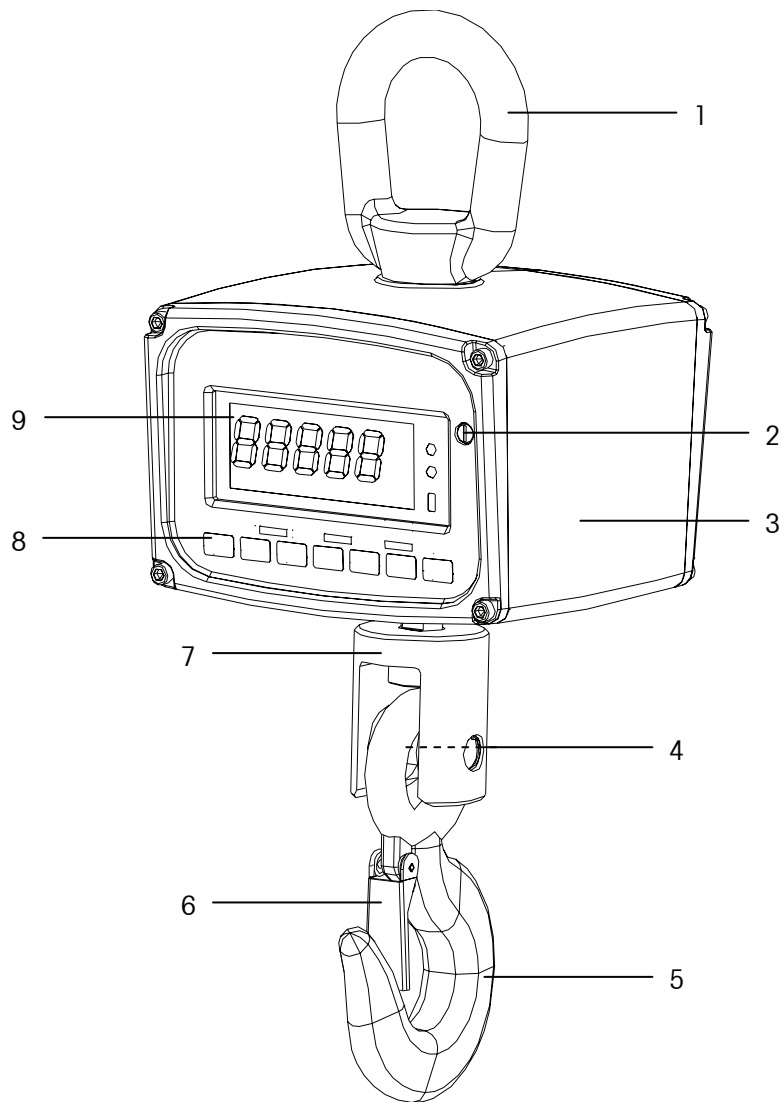

Figure 1-1. Front view of scale

TABLE 1-1. SCALE PARTS (front)

Item	Description
1	Shackle
2	Weights and Measures Sealing Screw
3	Scale Body
4	Retaining Pins (2)
5	Load Bearing Hook
6	Safety Latch (must be in place)
7	Connecting Tube
8	Control Buttons
9	Display

1.3 OVERVIEW OF PARTS AND CONTROLS (cont.)

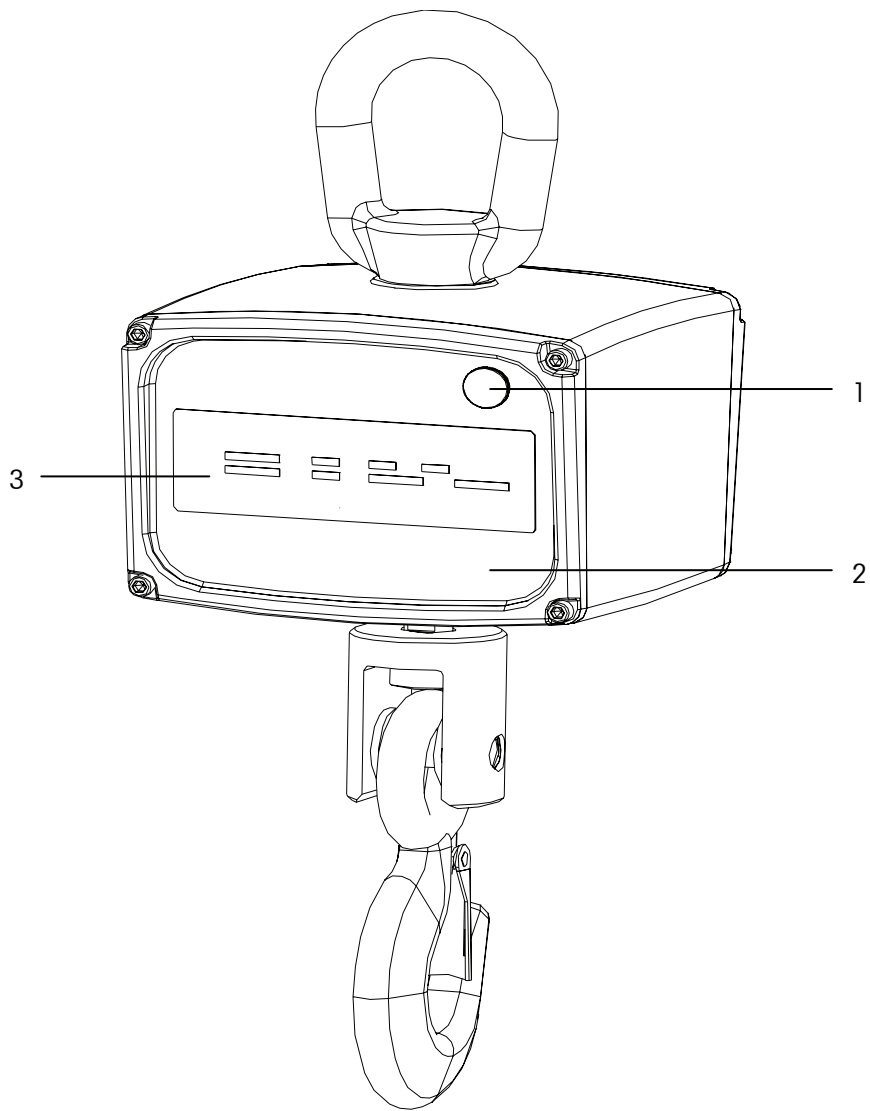

Figure 1-2. Rear view of scale

TABLE 1-2. SCALE PARTS (rear)

Item	Description
1	Battery Charger Connector Cover
2	Rear Cover
3	Data Plate

1.3 OVERVIEW OF PARTS AND CONTROLS (cont.)

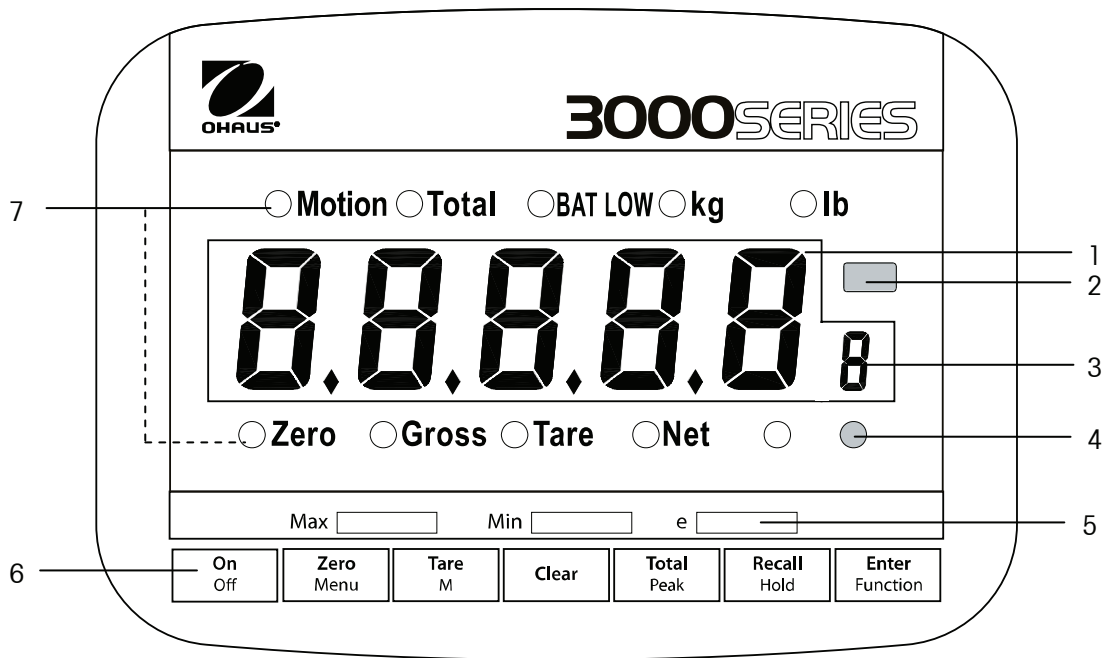

Figure 1-3. Controls and Indicators

TABLE 1-3. CONTROL PANEL

Item	Description	
1	Weight display	
2	Infrared receiving window for optional remote controller	
3	Display of commodity ID number (blank if no value entered)	
4	Light sensor	
5	Capacity data windows	
6	Control buttons (refer to Table 1-4)	
7	LED indicators (when lit or flashing, indicates):	
	Motion	Scale is in motion
	Total	Recalling data in accumulation memory
	Bat Low	Battery voltage is lower than the preset value
	kg	Weight unit is kilograms
	lb	Weight unit is pounds
	Zero	Scale is within $\pm 1/4d$ of gross zero
	Gross	Display is gross weight
	Tare	Display is tare weight
	Net	Display is net weight
	blank	Data being added into accumulation memory

1.3 OVERVIEW OF PARTS AND CONTROLS (cont.)

TABLE 1-4. CONTROL FUNCTIONS

Button		Function Description
	On Off	Turns the scale on or off.
	Zero Menu	Sets the scale to zero. When recalling accumulation data, clears the data.
Enter Function	+	Zero Menu
		Enters the User Menu.
		Tare M
		Performs a tare operation. During data entry, decreases the value.
Enter Function	+	Tare M
		Recalls the tare value.
		Clear
		In the Gross Mode, initiates scale self-test. In the Net Mode, clears tare and returns to Gross Mode. In the Hold Mode, clears the displayed value on hold.
		Total Peak
		Adds the current weight reading into Accumulation memory.
Enter Function	+	Total Peak
		Enters the Peak Hold Mode.
		Recall Hold
		Press repeatedly to recall and display the following in sequence: tare value, first 4 digits of total accumulated value, last 4 digits of total accumulated value, total number of weighments, return to Weighing Mode During data entry, increments the value.
Enter Function	+	Recall Hold
		Holds the displayed reading (Display Hold mode).

1.3 OVERVIEW OF PARTS AND CONTROLS (cont.)

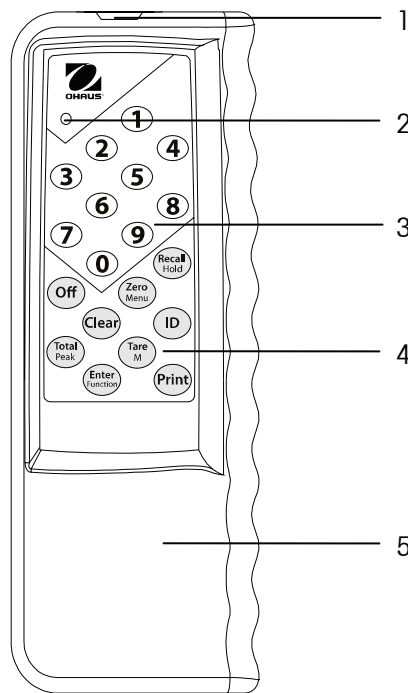

Figure 1-4. Remote Controller (optional)

TABLE 1-5. PARTS AND CONTROLS

Item	Description	
1	Infrared transmitting window	
2	Indicator light	
3	Numeric keypad	
4	Control Buttons (refer to Table 1-4, with the addition of the following):	
	ID	Initiates entry of commodity ID number via the numeric keypad
	Print	(not available with this product)
5	Rubber housing	

2. INSTALLATION

2.1 UNPACKING

Unpack the following items:

- Scale Unit
- Upper Shackle
- Lower Hook
- Transformer (Battery Charger)
- User Manual



This scale is compact and relatively heavy (see Section 7.1 weight specifications). Please take every precaution to ensure proper lifting and avoid bodily strain or injury, especially of the lower back.

- Have at least two people remove the scale from the shipping container.
- Use a power lifting device such as a crane or forklift.
- Secure the scale to ensure it does not drop when lifting.
- Do not stand under the scale.

2.2 HANGING THE SCALE

Hang the scale from the bottom hook of a crane, and lock the safety latch to prevent the scale from falling from the hook. The safety latch is a safety feature of the hook on the crane. If your crane does not have a safety latch, or the safety latch is damaged, please contact the crane manufacturer to obtain a hook with this safety feature.

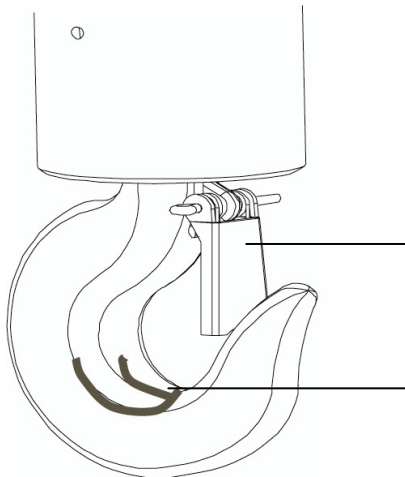

Ensure that the crane has this feature!

This safety latch prevents the scale from falling during a no load, or negative load, condition.

Area designated as saddle.

The scale's shackle should rest here.

2.3 HANDLING HOIST MOTION

- After the crane scale hook has been positioned over the load, lower it until the load can be attached to the scale hook. As the scale hook approaches this level, reduce the speed so that the lowering can be stopped smoothly and quickly.
- If slings are used to handle the load, the slings should be fully seated on the scale hook (saddle). With the scale hook latch closed, the scale hook should be started upward slowly until all slack has been taken out of the slings. Then ensure the load is properly balanced and the slings are properly positioned.



Follow all safety precautions (Section 1.1) and proper loading procedures (Section 2.4) during hoisting operations.

2.4 LOADING PROCEDURES

Please follow the proper loading procedures:

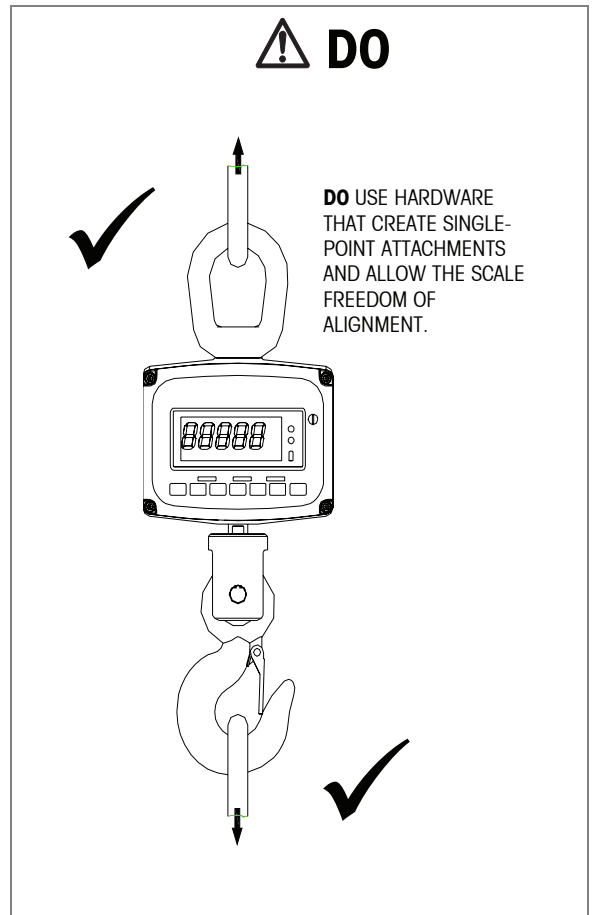
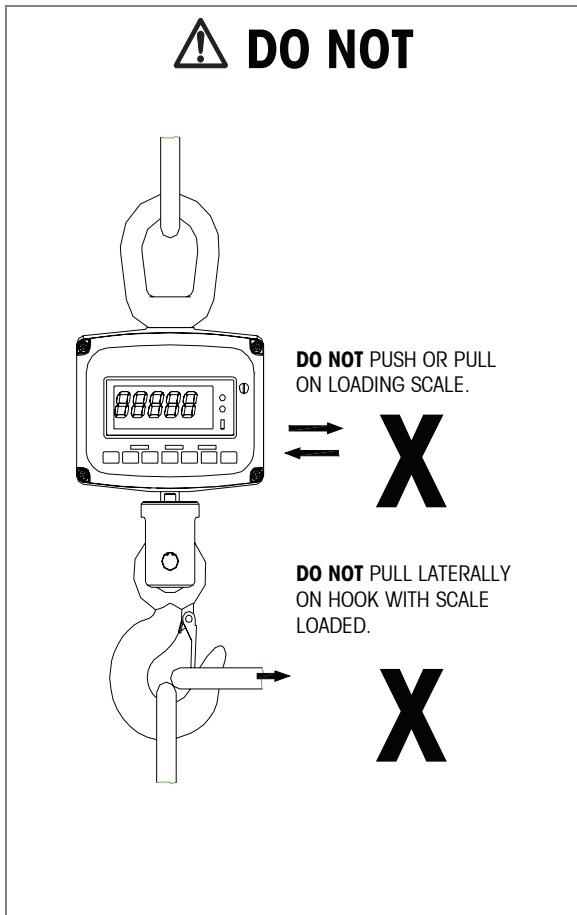
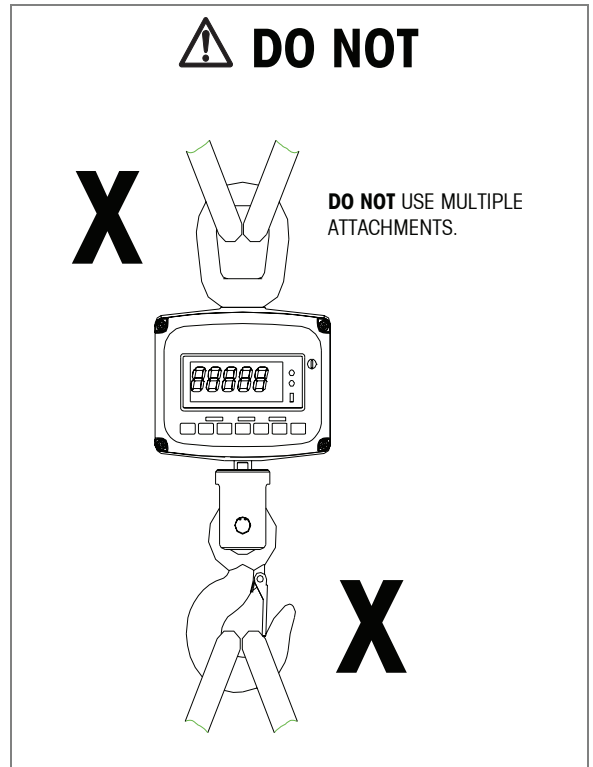
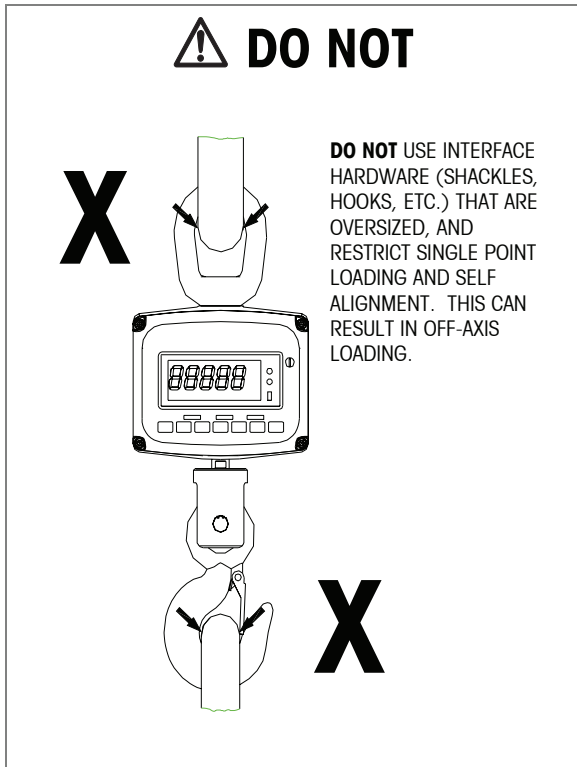

2.5 POWER SUPPLY

A rechargeable sealed lead acid battery (6V/7Ah) powers the scale.

2.5.1 Charging

Charge the battery with the battery charger through the charger connector at the rear of the scale (see Section 1.3, Figure 1-2, Item 1). Remove the plastic cap on the charging port of the scale, connect the charger to the charging port, then plug the charger into a proper power outlet.

- When the scale is used regularly, daily charging time is: 7 to 9 hours at 25°C/77°F; longer times at lower temperatures.
- Do not recharge the battery until it is almost or fully discharged—this will help extend battery life.
- When used properly, the battery can be effectively charged/discharged 300 times before operating time is significantly reduced
- Charge the battery at least every three months to keep it in good condition.
- The battery charge is shorter than normal if the battery is not used for more than two months. At this time, cycle the battery at least three times by charging it and using it until fully discharged. This returns the battery to the normal operating condition.
- The battery is not warranted since it is greatly influenced by individual use.
- Have the battery removed when the scale is not to be used for a long time.
- After considerable usage, the battery may need to be replaced should it begin not holding a charge.

2.5.2 Battery Indicators

- The indicator on the charger will indicate the charging or completed status.
- Charge the battery when the "Bat Low" indicator on the scale lights (see Section 1.3, Figure 1-3, item 7).
- Charge the battery immediately when the scale displays "L Bat", indicating that the battery charge is too low for the scale to work. The scale will power down automatically.
- In the Gross display, press **CLEAR** to initiate Self-Test and display battery capacity. The display reads "00000", "11111", ..., "99999", lights LED cursors, then displays the remaining battery capacity message "bAt X", where X = 4 (high), 3, 2, 1 (low).

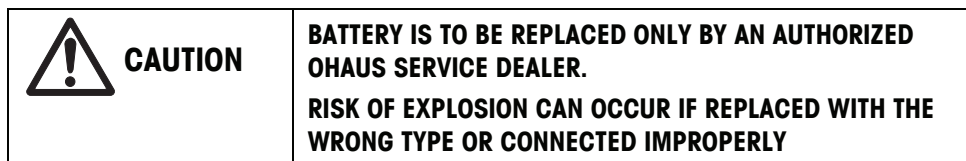

2.6 REMOTE CONTROLLER (Optional)

The remote controller operates the scale similarly to the control buttons on the scale, with the addition of **numeric (0-9)**, **ID** and **Print** buttons (see Section 1.3, Figure 1-4). Functions such as entering commodity ID, numeric settings (such as tare and menu settings) and printing (not available with this product) are accessed only through the remote controller. To enter the commodity ID, press **ID** then the number (0-9) via the numeric keypad.

Notes:

- When operating the remote controller, aim the transmitting window at the infrared receiving window on the scale's front housing (see Section 1.3, Figure 1-3, item 2).
- The remote controller cannot power up the scale (only turns the scale off).
- The remote controller can be operated at distances up to 33 feet (10m) from the scale.
- If the remote controller fails to function, clean the infrared receiving window on the front of the scale and the transmitting window on the front of the controller with alcohol and a clean cloth.

Remote Controller Battery Operation:

- The remote controller requires two (2) AA Alkaline batteries.
- To test the remote controller, press any key while observing the indicator light on the upper left-hand side of the control (see Section 1.3, Figure 1-4, item 5). If it fails to light when a key is pressed, replace the batteries.
- It is also recommended the batteries be replaced every 6 months.
- To replace the battery, remove the remote controller by pushing the head of the controller slowly out from the upper opening on the back of the yellow rubber housing (see Section 1.3, Figure 1-4, item 5), then pull out the controller. After replacing the batteries, slip the controller back into the rubber housing.

2.7 CALIBRATION

The scale comes pre-calibrated from the factory. If calibration is required, contact an authorized Ohaus service dealer.

3. OPERATION

3.1 TURNING THE SCALE ON/OFF

With the scale off, press **ON**. The scale powers up, displays the component number and software version number (e.g., "SL1.5"), performs a display test then enters the active weighing mode.

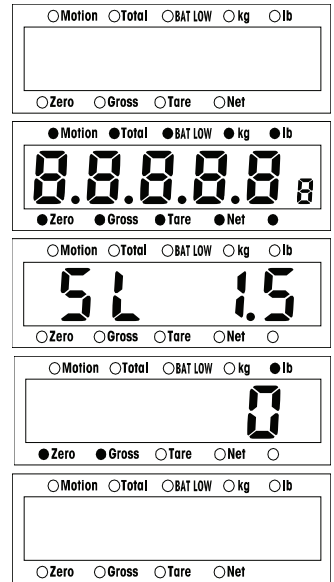

Press **OFF** to turn the scale off.

3.2 ZERO OPERATION

Zero can be set under the following conditions:

- Semi-automatically (manually) by pressing **ZERO**. If the gross value is within the zero range (ex. 50 lb) (see Section 4.3.1, setting F1.6.4), the display will read "0" and the Zero LED indicator will light.
- Automatically at Power On (initial zero). The power-on zero range must be less than the preset value (see Section 4.3.1, setting F1.6.3).
- **Notes:**
 - The scale will not accept a zero if the load is moving. The Motion LED indicator lights to indicate that the load is in motion (not stable).
 - In the Gross mode, if the Zero LED indicator is not lit, press **ZERO** to obtain best results.
 - The Zero LED indicator will light only when the load is $0 \pm 1/4$ displayed increment.

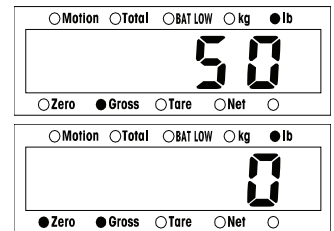

3.3 TARE OPERATION

3.3.1 Manual Tare

Press **TARE** to store the weight reading (ex. 50 lb) as the tare value. The Net LED indicator lights, and the scale displays "0".

Note: The scale will not accept a tare if the load is moving. The Motion LED indicator lights to indicate that the load is in motion (not stable).

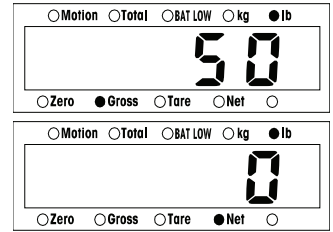

3.3.2 Numeric Tare

With the optional remote controller (see Section 2.6), enter the tare value (ex. 40 lb) via the numeric keys then press **TARE**. In this example, with a gross weight of 100 lb, the resulting net weight of 60 lb is displayed.

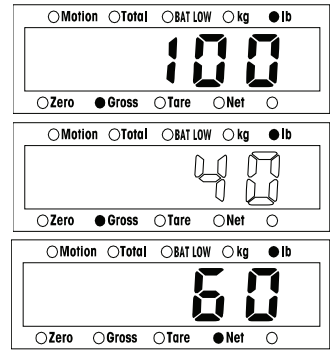

3.3.3 Clearing Tare

With a Net display, press **CLEAR** on the scale or the optional remote controller, then the display will show the gross weight.

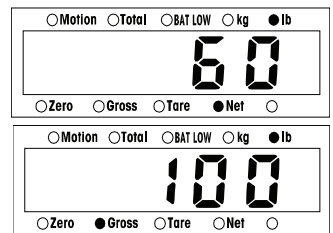

3.4 WEIGHING

Load ex. 2,000 lb (within full scale capacity) on the scale.

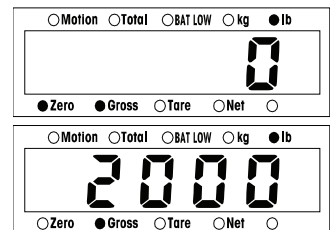

3.5 ACCUMULATION

In this mode, the displayed gross or net weight is accumulated manually or automatically. Enable Accumulation Mode to perform accumulation operation (see Section 4.3.2, setting F2.4.2).

Note: Accumulation is not available in Peak Hold Mode (see also Section 4.3.2, setting F2.5).

3.5.1 Manual Total

Turn on Manual Accumulation (see Section 4.3.2, setting F2.4.2).

With the scale loaded (ex. 2,000 lb gross) and stable, press **TOTAL** to add the displayed value and corresponding number of weighments into accumulation memory. The blank LED indicator lights for 3 seconds.

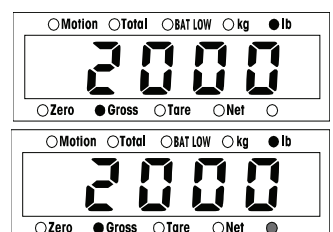

Remove the load then re-weigh and repeat process. The accumulation value and number of weighments are updated accordingly.

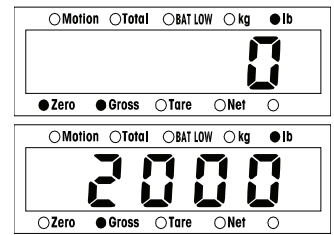

3.5.2 Auto Total

Turn on Auto Accumulation (see Section 4.3.2, setting F2.4.2).

Load the scale greater than or equal to the minimum accept limit (see Section 4.3.2, setting F2.4.1) (ex. 2,000 lb gross). When stable, the displayed gross (or net) value and the corresponding number of weighments are added into accumulation memory. The blank LED indicator lights for 3 seconds.

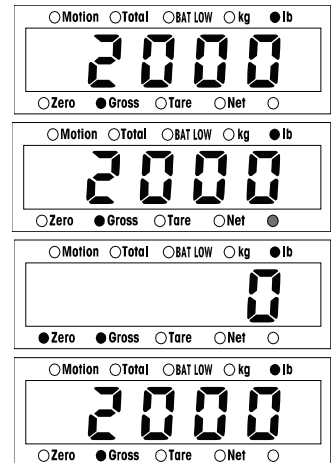

Remove the load then re-weigh. The accumulation value and number of weighments are updated accordingly.

Note: When the accumulated weight exceeds 8 digits (H 9999 / L 9999, see the following Section 3.5.3), or the total number of weighments exceeds 3 digits (999), the scale displays "FULL" and the blank LED status indicator (see Section 1.3, Figure 1-3, item 7) flashes for 5 seconds. This indicates that the accumulator is full and the last accumulation is invalid. Clear the accumulator at this time (see Section 3.5.4).

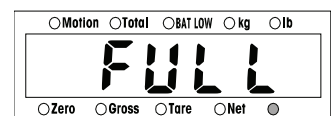

3.5.3 Recalling Accumulation Data

With or without a load on the scale (except in Peak Hold mode), press **RECALL** repeatedly to display the following:

- Tare value, then
- Total accumulated weight value (first 4 digits), then
- Total accumulated weight value (last 4 digits), then
- Total number of weighments, then
- Return to weighing mode

In this example, with the scale pre-loaded with 2,000 lb gross, the tare value = 0, total accumulated weight value = 22,000 lbs. (00022000), and total number of weighments = 11 (00011).

The Total LED lights when the accumulated weight value and total number of weighments are displayed.

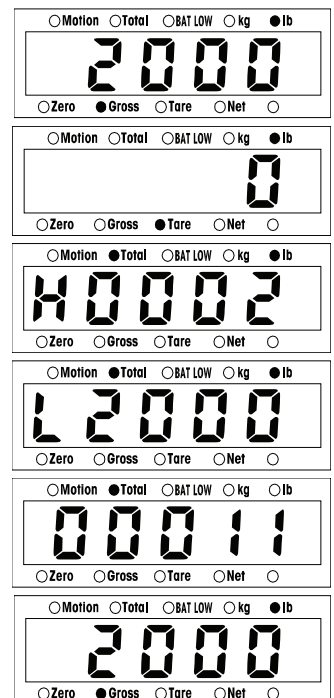

3.5.4 Clearing Accumulation Data

Press **RECALL** to recall accumulation data. When the first sequence of the total accumulation value is displayed, press **ZERO**. When "SURE" is displayed, press **ENTER** to confirm.

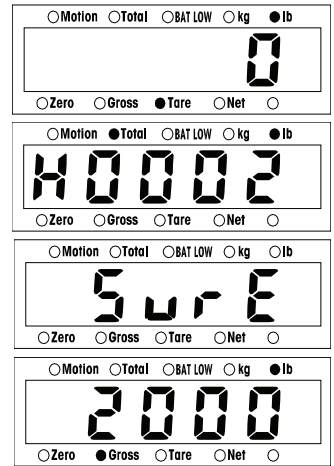

3.6 PEAK HOLD

In this mode, the maximum (peak) gross or net weight is held on the display until cleared.

Enable Peak Hold Mode to perform peak hold operation (see Section 4.3.2, setting F2.5).

At any time during weighing (ex. with 10 lb gross), press **FUNCTION** first, release, then press **PEAK**. The subsequent stable maximum weight detected (ex. 2,015 lb gross) is held on the display. Remove the weight then press **ZERO** to re-start peak hold operation.

Press **CLEAR** to exit peak hold operation.

Note: Accumulation is not available in Peak Hold Mode.

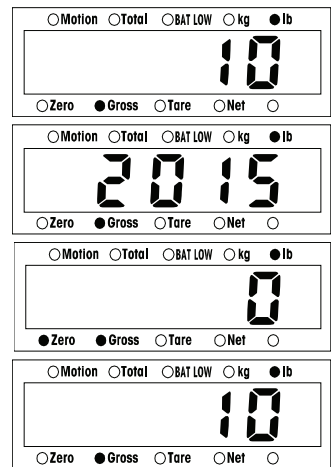

3.7 DISPLAY HOLD

In this mode, the displayed gross or net weight is held on the display until cleared.

At any time during weighing, press **FUNCTION** first, release, then press **HOLD**. The subsequent stable displayed weight (ex. 2,000 lb gross) is held on the display. Remove the weight then press **CLEAR** to clear the display.

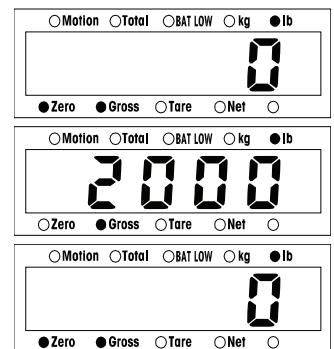

3.8 SLEEP MODE

The scale enters power-saving (sleep) mode if the scale remains inactive after 5 minutes (see Section 4.4.1, setting F3.1). The scale will display "SLEEP" at this time until the scale is used or a key on the scale is pressed.

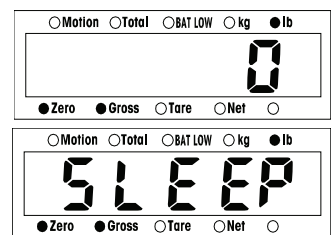

4. SCALE SETTINGS

4.1 MENU STRUCTURE

TABLE 4-1. USER PARAMETERS

SCALE SETUP ACCESS		MENU ACCESS			
F1 READOUT	F2 APPLICATION	F3 SPECIAL FUNCTION	F4 PRINT	F5 SELF-TEST	F6 MENU SET
F1.2 Filtering Level	F2.4.1 AccumulationLimit	F3.1 Sleep Mode	(No function in this product)	(Service Use Only)	F6.1 Finish Setup
F1.5 Tare Operation	F2.4.2 Accumulation Mode	F3.2 Brightness Level			
F1.6.2 Auto Zero Tracking	F2.5 Weighing Mode	F3.3 Battery Selection			
F1.6.3 Power-on Zero	F2.6 Unit Conversion	F3.4 ID Function			
F1.6.4 Key Zero	F2.7 (Service Use Only)	F3.7 Retain Zero Data			
F1.7.1 Motion Detection		F3.8 Remote Controller			
F1.8 Unit Selection					
F1.9 ... F1.14 (Service Use Only)					



Note: Shaded menus have no function in this product, or its settings should not be changed.

4.2 MENU NAVIGATION

Summary of button navigation functions in menu mode:

Enter Function	Allows entry into the displayed menu. Accepts the displayed setting and advances to the next menu item.
Tare M	Skips to the next menu or setting. During numerical data entry, shifts to the next digit.
Zero Menu	Returns to the previous menu.
Recall Hold	During numerical data entry, increments the value of the flashing digit.

4.3 SCALE SETUP ACCESS

	 WARNING	 CAUTION
	<p>DISCONNECT ALL POWER TO THIS UNIT BEFORE INSTALLING, SERVICING, CLEANING OR REMOVING THE FUSE. FAILURE TO DO SO COULD RESULT IN BODILY HARM AND/OR PROPERTY DAMAGE.</p>	<p>BEFORE CONNECTING OR DISCONNECTING ANY INTERNAL ELECTRONIC COMPONENT OR INTERCONNECTING WIRING BETWEEN ELECTRONIC EQUIPMENT, ALWAYS REMOVE POWER AND WAIT AT LEAST 30 SECONDS BEFORE ANY CONNECTIONS OR DISCONNECTIONS ARE MADE. FAILURE TO OBSERVE THESE PRECAUTIONS COULD RESULT IN DAMAGE OR DESTRUCTION OF THE EQUIPMENT OR BODILY HARM.</p>

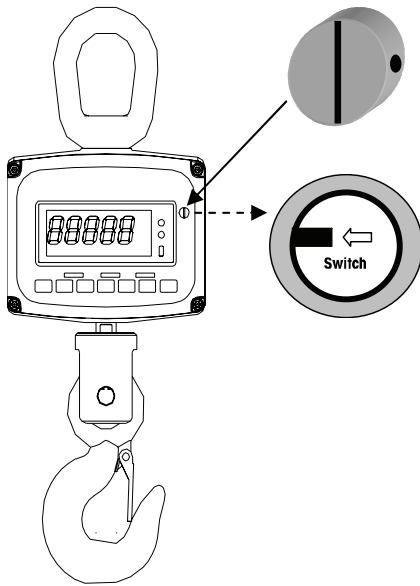

To access Scale Setup parameters:

1. Remove the sealing screw on the right side of the front housing of the scale.
2. Press the switch inside the sealing screw hole.
3. The scale enters Scale Setup and first displays "F1".

Note:

If the scale is sealed for approved applications (see Section 5), entering Scale Setup voids the weights and measures approval and the unit must be re-approved.

Figure 4-1. Scale Setup Access

4.3.1 Readout Menu (F1)

Press **Enter** to access Readout Menu parameters "F1.X", or press **Tare** to skip to the next menu "F2" (see Section 4.2 for Menu Navigation).

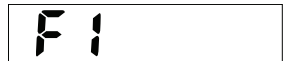

Filtering Level (F1.2 \times):

- 0 = Function disabled
- 1 = Low filtering
- 2 = Medium filtering (default)
- 3 = High filtering



Tare Operation (F1.5 \times):

- 0 = Function disabled
- 1 = Function enabled (default). Tare range: 0~100% (of full scale capacity)

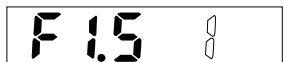

Zero and Auto Zero Tracking Sub-menu (F1.6):

Press **Enter** to access "F1.6" parameters, or press **Tare** to skip to the next menu "F1.7".



Auto Zero Tracking (F1.6.2 \otimes):

- 0 = Function disabled (default)
- 1 = Threshold value: $\pm 0.5d$ (d = scale divisions)
- 2 = Threshold value: $\pm 1d$
- 3 = Threshold value: $\pm 3d$

Power-on Zero (F1.6.3 \otimes):

- 0 = Function disabled
- 1 = Range: $\pm 2\%$ (of full scale capacity)
- 2 = Range: $\pm 20\%$ (default)

Key Zero (F1.6.4 \otimes):

- 0 = Function disabled
- 1 = Range: $\pm 2\%$ (of full scale capacity) (default)
- 2 = Range: $\pm 20\%$

Motion Detection Sub-menu (F1.7):

Press **Enter** to access "F1.7" parameters, or press **Tare** to skip to the next menu "F1.8".

Motion Detection (F1.7.1 \otimes):

- 0 = Function disabled
- 1 = Range: $\pm 0.5d$ (d = scale divisions) (default)
- 2 = Range: $\pm 1d$
- 3 = Range: $\pm 3d$

Unit Selection (F1.8 \otimes):

- 1 = kg (kilogram)
- 2 = lb (pound) (default)

F1.9 ~ F1.14:

These parameters are for service use only. **DO NOT** access or change these settings. Press **Enter** repeatedly to skip through the succeeding menus until "F2" is displayed.



4.3.2 Application Menu (F2)

Press **Enter** to access Application Menu parameters "F2.X", or press **Tare** to skip to the next menu "F3"



Application Group Sub-menu (F2.4):

Press **Enter** to access "F2.4" parameters, or press **Tare** to skip to the next menu "F3".



Accumulation Mode Sub-menu (F2.4.1):

Press **Enter** to access "F2.4.1" parameters, or press **Tare** to skip to the next menu "F2.5".



Accumulation Limit Setting (F2.4.1 X):

Sets the minimum acceptable weight which can be accumulated (value should be more than 10 scale divisions).

A second after accessing "F2.4.1", "00000" (or last value setting) is displayed with the left-most digit flashing. Press **Zero** to clear the existing setting.

Use **Tare** and **Recall** to change the setting, or key in the value directly from the optional remote controller. With the desired value displayed, press **Enter** to confirm and advance to "F2.4.2", or press **Zero** to cancel and return to "F2.4".



~1 second



Accumulation Function (F2.4.2 X):

- 0 = Function disabled (default)
- 1 = Manual Accumulation
- 2 = Auto Accumulation

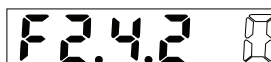

Weighing Mode (F2.5 X):

- 0 = Normal weighing mode (default)
- 1 = Peak Hold mode
- 2 = Setpoint mode (not available with this model)

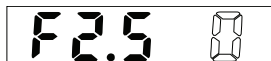

Unit Conversion (F2.6 X):

- 0 = No conversion (default)
- 1 = kg (if the current display unit is lb, converts pounds into kilograms)
- 2 = lb (if the current display unit is kg, converts kilograms into pounds)



Geographical Adjustment (F2.7 X):

This parameter is for service use only. **DO NOT** change the setting.

Press **Enter** to accept and skip to the next menu "F3". Press **Tare** successively to skip the next menus "F4" and "F5". When "F6" is displayed, see Section 4.4.4.



4.4 MENU ACCESS

Enter
Function

+

Zero
Menu

To access Menu Access parameters, press **ENTER** first, release, then press **MENU**. The scale enters Menu Access and first displays "F3".

Note: to quit Menu access, press **CLEAR** during the process to proceed directly to "F6" (see Section 4.4.4, Complete Menu Set).

4.4.1 Special Function Menu (F3)

Press **Enter** to access Special Function menu parameters "F3.X", or press **Tare** to skip to the next menu "F4" (see Section 4.2 for Menu Navigation).

F3

Sleep Mode (F3.1 \otimes):

0 = Function disabled

1 = Function enabled ("SLEEP" is displayed when the scale remains inactive after 5 minutes) (default)

F3.1 1

Display Brightness (F3.2 \otimes):

0 = Function disabled (default)

1 = Function enabled (display brightness dims automatically when the scale remains inactive after 5 minutes)

2 = Auto on/off (display brightness adjusts according to ambient light levels)

F3.2 0

Battery Selection (F3.3 X):

This function is not available for this model. **DO NOT** change the setting.

Press **Enter** to skip to the next menu "F3.4 X".

F3.3 0

ID Function (F3.4 \otimes):

0 = Function disabled (default)

1 = Function enabled (allows entry of commodity ID via the optional remote controller)

F3.4 1

Retain Zero Data (F3.7 \otimes):

0 = Function disabled (default)

1 = Function enabled (the scale returns to the last Zero and Gross/Net status when powering up)

F3.7 1

Remote Controller (optional) Function (F3.8 \otimes):

0 = Function disabled

1 = Function enabled (the remote controller is active)

F3.8 1

4.4.2 Printer Function (F4):

This function is not available for this model. **DO NOT** access or change the setting.

Press **Tare** to skip to the next menu "F5".

F4

4.4.3 Self-Test Function (F5):

These parameters are for service use only. **DO NOT** access or change these settings. Press **Tare** to skip to the next menu "F6".

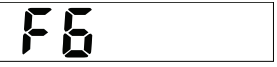

4.4.4 Complete Menu Set (F6):

Press **Enter** to complete Menu set "F6.1 X", or press **Tare** to start over Menu Access "F3" (or "F1" when menu is entered through Scale Setup Access--see Section 4.3).

Confirm Menu settings (F6.1 X):

- 1 = Saves settings, then exits to normal weighing mode.
- 2 = Restores the previous settings, then exits to normal weighing mode.

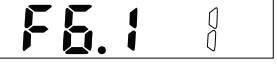
- 3 = Restores the factory default settings, then displays "SurE?". Press **Enter** to confirm then exit to normal weighing mode.



5. LEGAL FOR TRADE**5.1 VERIFICATION**



When the scale is used in trade or a legally controlled application, it must be set up, verified and sealed in accordance with local weights and measures regulations. The local weights and measures official or authorized service agent must perform the verification procedure.

It is the responsibility of the purchaser to ensure that all pertinent legal requirements are met. Please contact your local weights and measures office for further details.

5.2 SEALING

For jurisdictions that use the physical sealing method, the local weights and measures official or authorized service agent must apply a security seal to prevent tampering with the settings. The wire or paper seal method can be applied (see Section 1.3, Figure 1-1, Item 2 and Section 4.3, Figure 4-1 for the location of the sealing screw).

6. MAINTENANCE

	<div style="text-align: center;">  WARNING </div> <p>DISCONNECT ALL POWER TO THIS UNIT BEFORE INSTALLING, SERVICING, CLEANING, OR REMOVING THE FUSE. FAILURE TO DO SO COULD RESULT IN BODILY HARM AND/OR PROPERTY DAMAGE.</p>
---	---

6.1 CLEANING

- Clean the keypad and other surfaces with a soft cloth dampened with a mild window cleaner or detergent.
- **DO NOT** use any type of industrial solvent or chemicals.

6.2 REGULAR MAINTENANCE AND INSPECTION

Regular inspections and keeping maintenance records periodically by a qualified service technician are recommended.

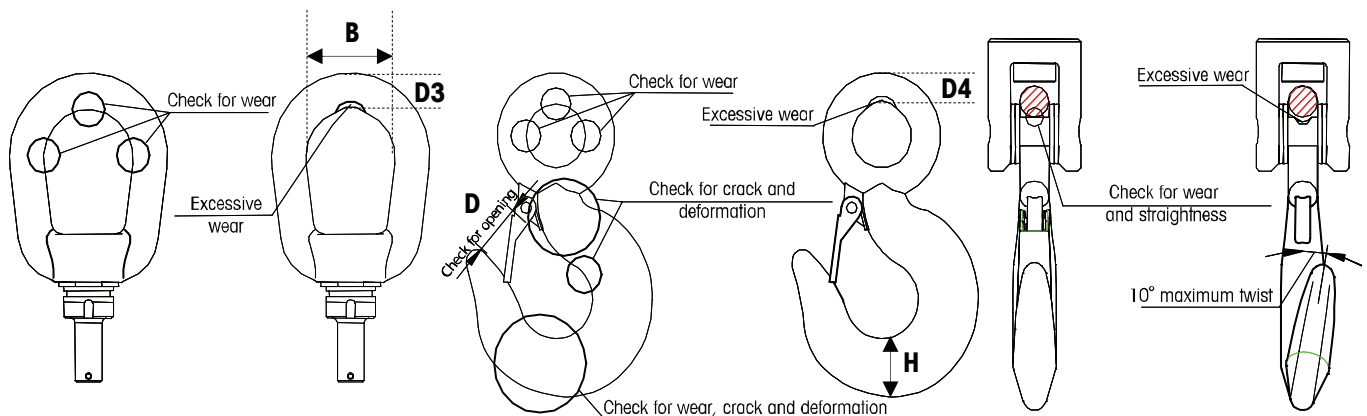

Figure 6-1

6.2.1 Connections

Regularly check connecting pieces, split pins and set screws for looseness or deformity, and replace or tighten them at once.

6.2.2 Surface Damage

Regularly check the shackle and hook surfaces for mechanical damage such as cracks, etc. Immediately discard and replace damaged parts.

6.2.3 Deformation

- Regularly check the opening of the hook. When the opening is 10% greater than the initial dimension, discard and replace the hook.
- Regularly check the twist deformation of the hook. When the twist angle of the hook body is greater than 10°, discard and replace the hook.
- The shackle and hook should not have any plastic deformation, or they must be discarded and replaced.

6.2.4 Abrasion and Corrosion

- Regularly check the shackle and hook for abrasion and corrosion. When the actual dimensions in use on the dangerous sections are less than 95% of their initial dimensions, discard and replace these parts.
- **DO NOT** repair the shackle and hook system by welding.
- Replace the secure latch periodically, and whenever it is damaged or broken. This will prevent the scale from falling should it encounter a no load or zero load.

6.3 DISPLAY MESSAGES

Display	Description	Remedy
E1	EPROM checkout error.	<ul style="list-style-type: none"> • Power off and on. • Replace PCB (service).
E2	Internal RAM checkout error.	
E3	EPROM checkout error.	
E35	Calibration test weight is too light.	Add additional test weight.
E37	The scale is not stable.	Recalibrate the scale (service).
Full	Data memory overflow.	Clear transaction record.
I _ _ _ I	Underload condition. Underload is below power-on auto zero limit.	<ul style="list-style-type: none"> • Add load to scale. • Check load cell cable connections for looseness (service). • Recalibrate the scale (service).
I ^ ^ ^ I	Overload condition. Overload is 9d greater than full scale capacity.	Reduce load on scale.
L bAt	Low battery voltage. Battery charge is too low for the scale to work, and the scale will power down automatically.	Charge the battery immediately, or after considerable usage, replace the battery should it begin not holding a charge.
SLEEP	Scale is on and inactive for 5 minutes.	Add load or press any key on the scale.

6.4 SERVICE INFORMATION

For service assistance in the United States, contact an authorized Ohaus Service Agent, or call toll-free 1-800-526-0659 between 8:00 AM and 5:00 PM Eastern Standard Time for an Ohaus Product Service Specialist.

7. TECHNICAL DATA

7.1 SPECIFICATIONS

Models:	DCR250	DCR500	DCR1000	DCR2000	DCR5000
Capacity x Readability (default)	250 x 0.1 lb 100 x 0.05 kg	500 x 0.2 lb 250 x 0.1 kg	1,000 x 0.5 lb 500 x 0.2 kg	2,000 x 1 lb 1,000 x 0.5 kg	5,000 x 2 lb 2,500 x 1 kg
Approved Resolution	n_{max} 5000				
Enclosure	IP65 painted cast aluminum alloy housing, galvanized hook and shackle				
Safe Overload	200% of rated full scale capacity				
Ultimate Overload	500% of rated full scale capacity				
Display	1" (25mm) high, 5-digit, 7-segment LED for weight display / 0.8" (20mm) high, 1-digit, 7-segment LED for ID / adjustable brightness level				
Weighing Units	lb, kg				
Extra Functions/Modes	Accumulation (manual or auto), Peak Hold, Display Hold, Pre-set Tare (with optional IR controller)				
Environmental Filtering	User selectable: off, low, medium, high				
Stabilization Time	Within 10 seconds				
Key Zeroing Range	$\pm 2\%$ or $\pm 20\%$ of full scale capacity				
Operating Temperature	4°F to 122°F (-20°C to 50°C)				
Power	6V 7Ah rechargeable lead acid battery – battery charger included (up to 150 hours operation between charging)				
Net Weight	26 lb (12 kg)			29 lb (13 kg)	
Shipping Weight	31 lb (14 kg)			33 lb (15 kg)	
Shipping Dimensions	21.2"L x 10.6"W x 12.2"H (54L x 27W x 31H cm)				

7.2 DRAWINGS AND DIMENSIONS

Dimensions:	H	D	$\phi 1$	F	$\phi 2$	$\phi 3$
DCR250 ~ DCR2000	14.9"	1.0"	1.2"	2.4"	1.8"	0.6"
DCR5000	17.4"	1.1"				

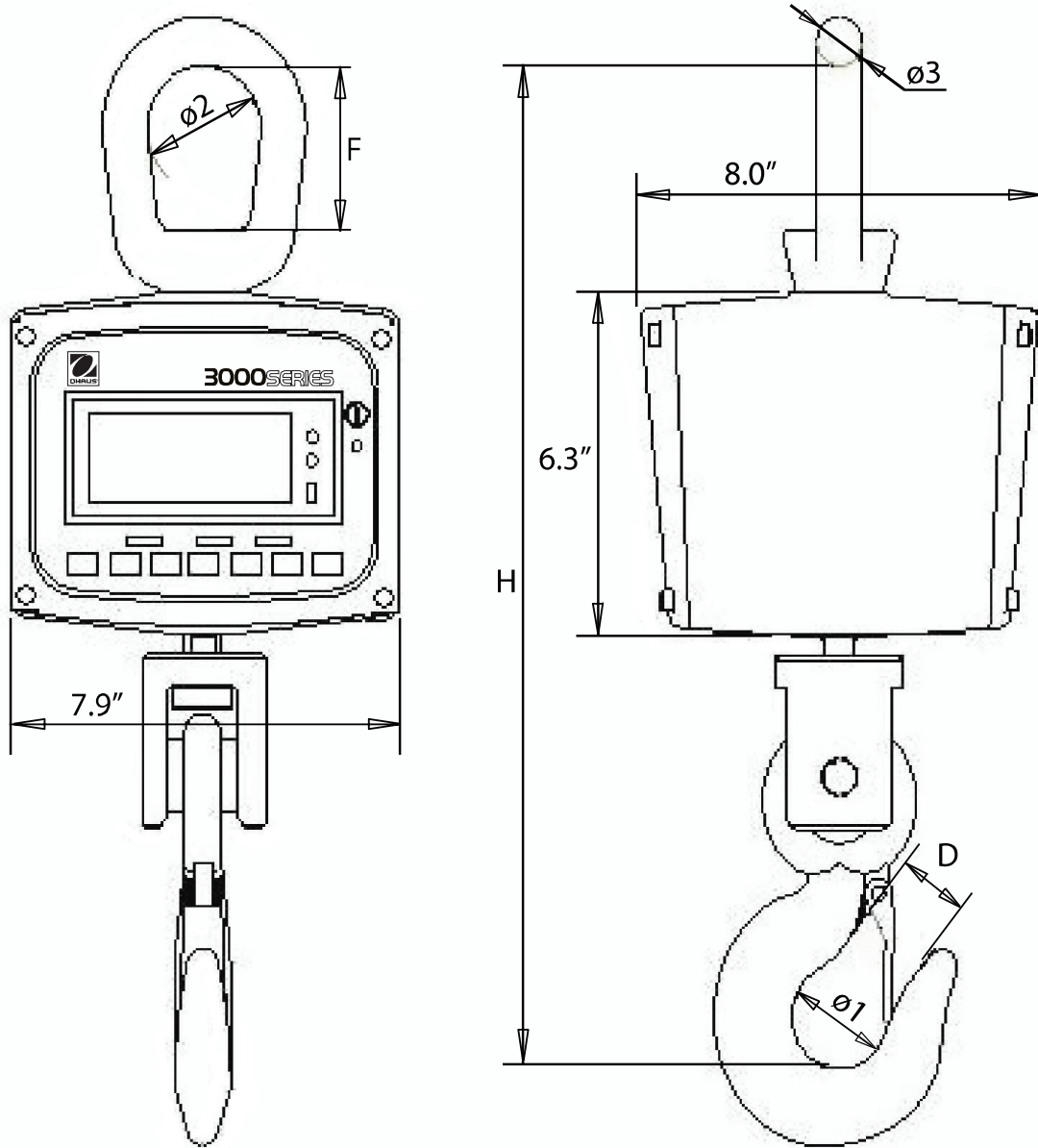

Figure 7-1. Overall Dimensions

7.3 COMPLIANCE



This product conforms to the EMC directive 2004/108/EC and the Low Voltage Directive 2006/95/EC. The complete declaration of Conformity is available from Ohaus Corporation.



CAN/CSA C22.2 No. 60950-1-03
UL 60950-1:2003



Disposal

In conformance with the European Directive 2002/96 EC on Waste Electrical and Electronic Equipment (WEEE) this device may not be disposed of in domestic waste. This also applies to countries outside the EU, per their specific requirements.

Please dispose of this product in accordance with local regulations at the collecting point specified for electrical and electronic equipment.

If you have any questions, please contact the responsible authority or the distributor from which you purchased this device.

Should this device be passed on to other parties (for private or professional use), the content of this regulation must also be related.

For disposal instructions in Europe, refer to www.ohaus.com/weee.

Thank you for your contribution to environmental protection.

FCC Note

This equipment has been tested and found to comply with the limits for a Class A digital device, pursuant to Part 15 of the FCC Rules. These limits are designed to provide reasonable protection against harmful interference when the equipment is operated in a commercial environment. This equipment generates, uses, and can radiate radio frequency energy and, if not installed and used in accordance with the instruction manual, may cause harmful interference to radio communications. Operation of this equipment in a residential area is likely to cause harmful interference in which case the user will be required to correct the interference at his own expense.

Industry Canada Note

This Class A digital apparatus complies with Canadian ICES-003.

ISO 9001 Registration

In 1994, Ohaus Corporation, USA, was awarded a certificate of registration to ISO 9001 by Bureau Veritas Quality International (BVQI), confirming that the Ohaus quality management system is compliant with the ISO 9001 standard's requirements. On May 15, 2003, Ohaus Corporation, USA, was re-registered to the ISO 9001:2000 standard.

LIMITED WARRANTY

Ohaus products are warranted against defects in materials and workmanship from the date of delivery through the duration of the warranty period. During the warranty period Ohaus will repair, or, at its option, replace any component(s) that proves to be defective at no charge, provided that the product is returned, freight prepaid, to Ohaus.

This warranty does not apply if the product has been damaged by accident or misuse, exposed to radioactive or corrosive materials, has foreign material penetrating to the inside of the product, or as a result of service or modification by other than Ohaus. In lieu of a properly returned warranty registration card, the warranty period shall begin on the date of shipment to the authorized dealer. No other express or implied warranty is given by Ohaus Corporation. Ohaus Corporation shall not be liable for any consequential damages.

As warranty legislation differs from state to state and country to country, please contact Ohaus or your local Ohaus dealer for further details.



Ohaus Corporation
19A Chapin Road
P.O. Box 2033
Pine Brook, NJ 07058-2033, USA
Tel: (973) 377-9000
Fax: (973) 944-7177
www.ohaus.com

With offices worldwide



* 8 0 2 5 3 1 3 0 *

P/N 80253130 © 2009 Ohaus Corporation, all rights reserved

Printed in China